

Superior DoorProtect G3 Fibra user manual

Updated January 12, 2026



Superior DoorProtect G3 Fibra is a wired opening, shock, and tilt detector. It supports connection of a third-party wired detector with a normally closed (NC) contact type. The device is designed for indoor use only. Complies with Grade 3 (EN 50131) requirements.



Superior DoorProtect G3 Fibra is compatible with [Superior Hub Hybrid \(2G\)](#) and [Superior Hub Hybrid \(4G\)](#). Connection to other [hubs](#), [radio signal range extenders](#), [ocBridge Plus](#), and [uartBridge](#) is not provided.

The detector exchanges data with the hub using the secure Fibra wired communication protocol. Wired communication can be up to 2,000 meters long when connected using the U/UTP cat.5 twisted pair cable.

Superior DoorProtect G3 Fibra is a part of the Fibra product line of wired devices. Only accredited Ajax Systems partners can sell, install, and administer Fibra products.

Buy Superior DoorProtect G3 Fibra

Functional elements



1. LED indicator.
2. Superior DoorProtect G3 Fibra detector.
3. Big magnet.
4. Spacer to mount the detector and/or magnet on the surface (2 pcs. in the set).
5. Mounting panel of the detector enclosure. It is used to mount the device to the spacer or directly to the surface.
6. QR code with the device ID. It is used to add the detector to the Ajax system.
7. Perforated part of the detector enclosure. Do not break it off. Necessary for tamper triggering in case of any attempt to detach the detector from the surface.
8. Perforated part of the detector enclosure for routing cables through the wall.

9. Perforated part of the detector enclosure for routing cables from the bottom or top of the detector.
10. Tamper.
11. Terminals to connect the detector.
12. Hole for attaching the detector with a screw.
13. Screw.

Operating principle

Superior DoorProtect G3 Fibra is a wired opening, shock, and tilt detector. The device consists of two parts. The first part is the detector with two reed switches, the magnetic masking, shock, and tilt sensor. The second part is the magnet that is needed to detect the opening. All sensors of the detector work independently. Each sensor of the detector can be enabled or disabled in Ajax apps.

The opening is detected by a reed switch built into the detector and a magnet. When the magnet is closer or further, the reed switch changes the state of the contacts and notifies of opening or closing.



Superior DoorProtect G3 Fibra has two reed switches so that the magnet can be installed both on the left or right of the detector. The device works correctly with one magnet on one side only. If magnets are attached on both sides, Superior DoorProtect G3 Fibra cannot detect the opening correctly.

The **shock sensor** detects attempts to knock out a window or door and reacts to vibration when attempts are made to knock out a lock or break a door.

The **tilt sensor** detects the vertical axis deviation of a device. Before the system is armed, the sensor remembers the initial position and is triggered if the deviation is more than 5° (depending on the settings). This allows it to

protect windows, including skylights, and arm the system when the window is in ventilation mode. You just need to disable the main detector in the settings in advance.

If the armed device detects the opening and closing of a door or a window, impact, and changes in angle, it instantly sends an alarm to the hub. The hub activates the sirens connected to the system, triggers scenarios, and notifies users and the security company. All detector alarms and events are recorded in the events feed of the Ajax apps.



The detector does not switch to armed mode instantly. The switching time depends on the delay when leaving (specified in the [detector settings](#)) and the hub–detector polling interval. The polling interval specified in the Fibra settings, by default its meaning is 36 seconds. In the first case, the delay is set by a user or a PRO with admin rights. In the second case, the delay occurs because the hub takes one polling interval to notify the detector about the security mode change.

[How Ajax notifies users of alarms](#)

[More about Ajax opening detectors](#)

Magnetic masking protection

The device detects an attempt to mask the main magnet of Superior DoorProtect G3 Fibra with a fraudulent magnet. The built-in sensor compares the current magnetic field value with the one recorded during calibration and identifies the differences. If differences are detected, users and the central monitoring station (CMS) receive a notification about the masking. The system allows users to select when the device detects magnetic masking: always or only when the detector is armed.

The masking sensor should be calibrated immediately after installation or if the installation location has been changed.

Fibra data transfer protocol

The detector uses Fibra technology to transmit alarms and events. It is a wired data transfer protocol for fast, reliable two-way communication between the hub and connected devices.

[Learn more](#)

Sending events to the monitoring station

The Ajax system can transmit alarms to the [PRO Desktop](#) monitoring app as well as the central monitoring station (CMS) in the formats of **SurGard (Contact ID)**, **SIA (DC-09)**, **ADEMCO 685**, and [other protocols](#).

Superior DoorProtect G3 Fibra can transmit the following events:

1. Opening sensor (reed switch) alarm/recovery.
2. Opening sensor (reed switch) malfunction/recovery.
3. Accelerometer malfunction/recovery.
4. Magnetic masking sensor malfunction/recovery.
5. Masking with a fraudulent magnet and recovery.
6. Alarm/recovery of a third-party detector with a normally closed (NC) contact type.
7. Tamper alarm. Tamper recovery.
8. Low supply voltage and voltage return to normal values.
9. Loss and restoration of connection with the hub.
10. Permanent deactivation/activation of the detector.

11. One-time deactivation/activation of the detector.

When an alarm is received, the operator of the security company monitoring station knows what happened and precisely where to send a fast response team. The addressability of Ajax devices allows sending events to the **PRO Desktop** or the CMS, the type of the device, its name, security group, and virtual room. The list of transmitted parameters may differ depending on the type of CMS and the selected communication protocol.



You can find the device ID, loop (zone) number, and line number in the device [States](#).

Selecting the installation site

When choosing where to place Superior DoorProtect G3 Fibra, consider the parameters that affect its operation:

- Fibra signal strength.
- The length of the cable for connecting the detector.
- Detection zone.

Consider the recommendations for placement when developing a project for the system of the facility. The Ajax system must be designed and installed by specialists. A list of recommended partners is [available here](#).

Installation recommendations

Positioning of the magnet relative to the sensor depends on installation placement and surface material.

Installation on metal surfaces

In the case of installation on **metal surfaces** (e.g. in a safe):

- The distance between the detector and the magnet should be 5 mm maximum.
- Make sure to use spacers.
- The distance between the detector and a third-party electromagnet (e.g. a door closer) must be more than 1 cm.



Installation on non-metallic surfaces

In the case of installation on **non-metallic surfaces** (e.g. on a plastic window or wooden door):

- The distance between the detector and the magnet should be 1 cm maximum.
- Spacers are optional.
- The distance between the detector and a third-party electromagnet (e.g. a door closer) must be more than 1 cm.



Superior DoorProtect G3 Fibra can be installed on sliding systems and roller shutters. If the magnet slides over the detector for a long time during closing/opening, false alarms are possible. To avoid this, disable the magnetic masking detection function.

The Superior DoorProtect G3 Fibra working distances

Relatively to the detector, the magnet can move along three axes: X (X1), Y, or Z. It depends on the Superior DoorProtect G3 Fibra installation location. For example:

- X-axis (or X1): on the roller shutter.
- Y-axis: on the sliding door.
- Z-axis: on the window.

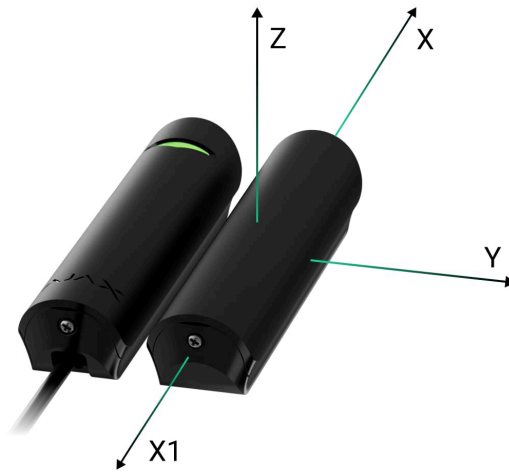

Axis	Magnet on the non-ferromagnetic surfaces (e.g., wooden doors)		Magnet on the ferromagnetic surfaces (e.g., metal doors)	
	Removal distance, mm	Approach distance, mm	Removal distance, mm	Approach distance, mm
X	26	19	24	16
X1	17	11	17	10
Y	28	16	26	15
Z	42	24	38	23



Do not exceed the boundary distance between the detector and the magnet. This may cause false alarms or detector malfunction (it will not react to the closing/opening of the door or window).

What are spacers for:

1. To install the detector or the magnet on a metal surface.
2. To reduce the distance between the detector and the magnet. For example, when you need to align the magnet with the detector on a door

or window.



If the window has a ventilation mode, the detector should be installed on the upper part of the window. Otherwise, when the window is opened for ventilation, the detector gets closer to its own magnet and may perceive it as an attempt to mask it. To avoid false alarms, install the detector on the upper part of the window.





You can rotate the detector 90° relative to the magnet to reduce the distance between the detector and the magnet.

You do not need to install a magnet near the detector if you want to use only the shock and/or tilt sensor. Disable the opening sensor and the magnetic masking sensor in the Superior DoorProtect G3 Fibra settings.

How not to install the detector

1. Outdoors. This can lead to false alarms and detector failure.
2. With two magnets at a time. The detector recognises one magnet only on one side of the detector – left-hand or right-hand.
3. With a magnet installed at a distance that does not comply with the recommendations. This may result in false alarms or malfunction of the detector – it will not react to the closing/opening of the door or window.
4. Inside premises where temperature and humidity values do not correspond to the operating parameters. It can damage the detector.
5. In places with low or unstable Fibra signal strength.
6. Along with other magnets. This may result in false alarms due to magnetic masking detection. If the detector is installed on a door with a door closer, the **High** sensitivity level should not be set.
7. Asymmetrical to the magnet.

Fibra signal strength

Fibra signal strength is the ratio of undelivered or corrupted data packages to those expected over a specific time. The icon  in the **Devices**  tab in Ajax apps indicates the signal strength:

- **Three bars** – excellent signal strength.
- **Two bars** – good signal strength.
- **One bar** – low signal strength; stable operation is not guaranteed.

- **Crossed out icon** – no signal; stable operation is not guaranteed.

What is Fibra Signal Strength Test

Detection zone

When choosing where to place the detector, perform the Detection Zone Test. This allows you to check the operation of the device and ensure that the detector responds correctly to the opening and closing of a door or a window, impact, and changes in angle.

Lines Power Test

The test simulates the maximum energy consumption of devices connected to the hub. If the system passes the test successfully, all its devices have enough power in any situation. After the test, the app displays a notification with the status of each line:

- Test passed.
- Test passed with malfunctions.
- Test failed.

What is Lines Power Test

Designing the system project

It is crucial to properly design the system project to install and configure the devices correctly. The project must consider the number and types of devices at the object, their exact location and installation height, the length of wired Fibra lines, the cable type, and other parameters.

Tips for designing the Fibra system project

Superior DoorProtect G3 Fibra can be connected at any point of the Fibra line. Wired communication can be up to 2,000 meters long when connected using the U/UTP cat.5 twisted pair cable.



Ajax systems support **Beam** and **Ring** topologies.

[Learn more](#)

Cable length and type

Recommended cable types for connecting Superior DoorProtect G3 Fibra to the hub:

- U/UTP cat.5, 4 × 2 × 0.51, copper conductor.
- Signal cable 4 × 0.22, copper conductor.



The wired connection range may vary if you use a different cable type. No other types of cables have been tested.

Verification using a calculator

We have developed the [Fibra power supply calculator](#) to ensure that the project is designed correctly and the system will work in practice. It helps to check the communication quality and cable length for wired Fibra devices when designing the system project.

Preparing for installation

Cable arrangement

When preparing to lay cables, check the electrical and fire safety regulations in your region. Strictly follow these standards and regulations. Tips for cable arrangement are available in [the article](#).

Cable routing

We recommend you carefully read the [Selecting the installation site](#) section before installation. Do not deviate from the system project. Violating the basic Superior DoorProtect G3 Fibra installation rules and the recommendations of this manual may lead to incorrect operation and loss of connection with the device. Tips for cable routing are available in [the article](#).

Preparing cables for connection

Remove the insulating layer and strip the cable with a special insulation stripper. The ends of the wires inserted into the device terminals must be tinned or crimped with a sleeve. It ensures a reliable connection and protects the conductor from oxidation. Tips for preparing the cables are available in [the article](#).

Installation and connection



Before installing Superior DoorProtect G3 Fibra, ensure that the optimal detector location has been selected and meets the requirements of this manual. Cables must be hidden from view and located in a difficult place for intruders to access to reduce the likelihood of sabotage. Ideally, mount them in the walls, floor, or ceiling. Before final installation, run the line [detection zone test](#) and [Fibra signal strength test](#).

To mount a detector:

1. Turn off the power of lines in the [Ajax PRO app](#):

1. Hub → Settings  → Lines → Lines Power Supply.

2. Route the cable to connect Superior DoorProtect G3 Fibra to the hub casing. Connect the wires to the required hub line.

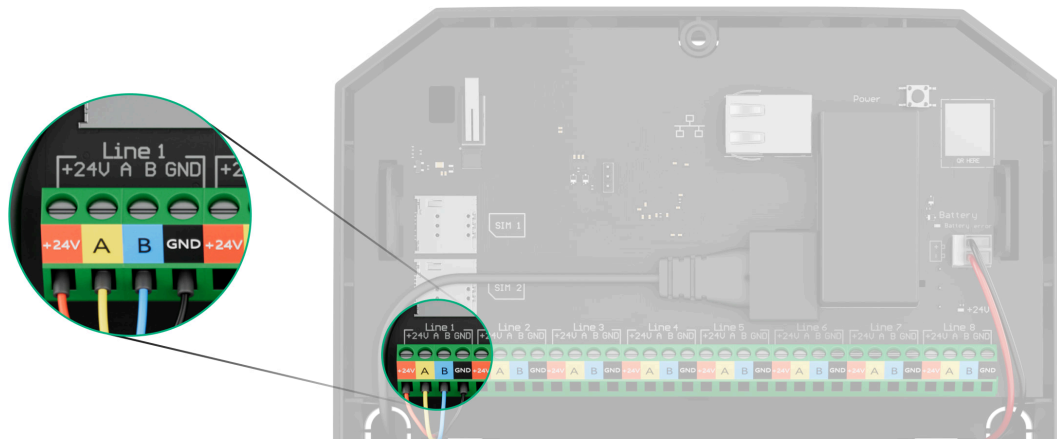

+24V – 24 V_{DC} power terminal.

A, B – signal terminals.

GND – ground.

3. Remove the back panel of the detector. Carefully break out the perforated part to output the cable.
4. Run the cable from the hub into the detector enclosure through the hole that was made.



5. Connect the wires to the terminals according to the figure below. Be sure to follow the polarity and connection order of the wires. Securely fasten the cable to the terminals.

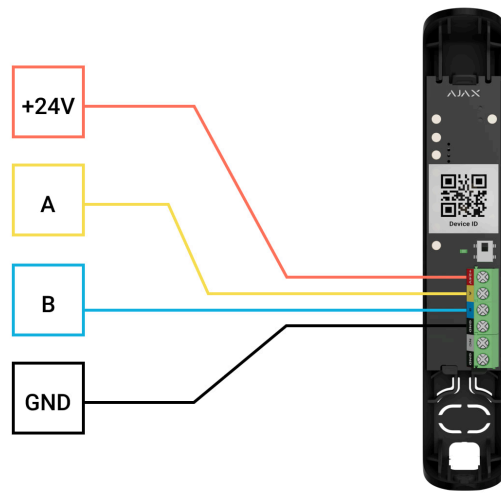

+24V – 24 V= power terminal.

A, B – signal terminals.

GND – ground.

6. If the detector is not the last one in the connection line, prepare a second cable in advance. The ends of the wires of the first and second cables, which will be inserted into the detector terminals, must be tinned and soldered together or crimped with special tips.
7. If the detector is the last one in the line and the **Beam connection (Radial wiring)** is used, install a terminating resistor. Connect it to the signal terminals of the device. When the **Ring connection method** is used, a terminating resistor is not needed.



We recommend using the **Ring connection method** (hub–device–hub). If the ring is broken, not a single device will be disabled. In this case, two beams are formed, which will continue to operate normally and transmit events to the hub. If the ring is broken, the users and the security company receive a notification.

8. Temporarily secure the detector to the window or door frame at the selected installation place. This is necessary for testing the detector.
9. Temporarily attach the magnet.

10. Turn on the power supply of lines in the [Ajax PRO app](#):

1. Hub → Settings  → Lines → Lines Power Supply.

11. [Add the detector to the system](#).

12. Run the [functionality testing](#).

13. If the detector passes the tests, fix the detector with bundled screws.
Use at least two fixing points (one is in the perforated part of the mount above the tamper). When using other fasteners, ensure they do not damage or deform the mounting panel.



The front lid of Superior DoorProtect G3 Fibra can be rotated 180° during installation. You can conveniently run the wires from the top or bottom. If the wires are routed from the bottom of the detector, the magnet must be mounted in such a way that the screw is also positioned from the bottom.



Connecting a third-party wired detector

You can connect a wired NC (normally closed) to Superior DoorProtect G3 Fibra.

Superior DoorProtect G3 Fibra does not power a third-party detector. It should be connected separately. For the type and voltage of the third-party detector, refer to the device documentation or contact the manufacturer's support service.

Install a third-party detector at a distance no more than 1 meter away from Superior DoorProtect G3 Fibra. Increasing the length of the wire degrades the quality of communication between devices.

To connect a third-party wired detector:

1. Turn off the power of lines in the Ajax PRO app:

1. Hub → Settings ⚙️ → Lines → Lines Power Supply.

2. Remove the front lid of Superior DoorProtect G3 Fibra.

3. Route the cable of the third-party wired detector into the Superior DoorProtect G3 Fibra enclosure.

4. Connect the wired detector to the Superior DoorProtect G3 Fibra terminals.

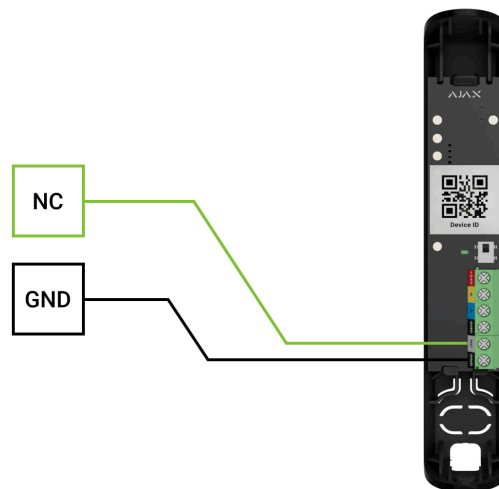

NC – connection terminal

GND – ground.

5. Turn on the power supply of lines in the Ajax PRO app:

1. Hub → Settings ⚙️ → Lines → Lines Power Supply.

6. Enable the **External contact** option in the Superior DoorProtect G3 Fibra [settings](#).
7. Check the operation of the connected wired detector. If an external contact is triggered, you receive a notification.

Connect a wired roller shutter motion detector with a normally closed (NC) contact type to Superior DoorProtect G3 Fibra to receive an alarm when the roller shutters open.

[How to connect a roller shutter motion detector to Superior DoorProtect G3 Fibra](#)

Adding to the system



Superior DoorProtect G3 Fibra is compatible only with [Superior Hub Hybrid \(2G\)](#) and [Superior Hub Hybrid \(4G\)](#). Only verified partners can add and configure Fibra devices in [Ajax PRO apps](#).

[Types of accounts and their rights](#)

Before adding a device

1. Install an [Ajax PRO app](#).
2. Log in to a [PRO account](#) or create a new one.
3. Select a space or create a new one.

[What is a space](#)

[How to create a space](#)



The **space** functionality is available for apps of such versions or later:

- Ajax Security System 3.0 for iOS;
- Ajax Security System 3.0 for Android;
- Ajax PRO: Tool for Engineers 2.0 for iOS;
- Ajax PRO: Tool for Engineers 2.0 for Android;
- Ajax PRO Desktop 4.0 for macOS;
- Ajax PRO Desktop 4.0 for Windows.

4. Add at least one virtual room.

5. Add a compatible hub to the space. Ensure the hub is switched on and has internet access via Ethernet, Wi-Fi, and/or mobile network.

6. Ensure the space is disarmed, and the hub is not starting an update by checking statuses in the Ajax app.

How to add Superior DoorProtect G3 Fibra

Two ways to add devices are available in the Ajax PRO app: automatically and manually.

Automatically Manually

To add a device automatically:

1. Open the Ajax PRO app. Select the hub to which you want to add Superior DoorProtect G3 Fibra.
2. Go to the **Devices**  tab and click **Add Device**.

3. Select **Add All Fibra Devices**. The hub will scan the Fibra lines. After scanning, all devices connected to the hub that still need to be added to the system will be shown.



Scanning is also available in the **Lines** menu:
Hub → **Settings** → **Lines** → **Add All Fibra Devices**.

4. Select the device from the list. After pressing, the LED indicator will flash to identify this device.
5. Set the device name, and specify the room and security group if **Group Mode** is enabled. Press **Save**.

The detector connected to the hub will appear in the list of hub devices in the Ajax app.



Device status updating depends on the Fibra settings; the default value is 36 seconds.

If the connection fails, check the wired connection's correctness and try again. If the maximum number of devices (100 for Superior Hub Hybrid) has already been added to the hub, you will receive an error notification while adding.

Superior DoorProtect G3 Fibra only works with one hub. The detector stops exchanging data with the previous hub when pairing with a new one. When Superior DoorProtect G3 Fibra is added to a new hub, it remains in the list of devices on the previous hub. You can remove it manually.

Functionality testing

Available for Superior DoorProtect G3 Fibra:

- **Fibra Signal Strength Test** – to determine the strength and stability of the signal at the device installation site.
- **Detection Zone Test** – to check how the detector registers the opening and closing of a door or a window, impact, and changes in angle at the device installation site.
- **Calibration of Masking Sensor** – to register the magnetic field's value at the detector's installation site. This value will be taken as normal. Calibration is performed when the opening sensor's is closed.
- **Device Self-Test** – to check if the built-in sensors of the detector operate properly.

Malfunctions

When a malfunction is detected (for example, there is no connection via the Fibra protocol), the Ajax app displays a malfunction counter in the upper left corner of the device icon.











All malfunctions are shown in the detector **States**. Fields with malfunctions will be highlighted in red.





A malfunction is displayed if:

- The detector temperature is outside acceptable limits.
- The detector enclosure is open (tamper is triggered).
- No connection with the hub via Fibra.
- The opening sensor is faulty. Magnetic masking detection is disabled.
- Accelerometer is faulty.
- Magnetic masking sensor is faulty.

Icons

The icons display some Superior DoorProtect G3 Fibra states. You can check them in the Ajax apps on the **Devices**  tab.

Icon	Meaning
	Fibra Signal Strength – displays the signal strength between the hub and the device. Recommended values: 2–3 bars. Learn more
	The detector operates in the Always Active mode. Learn more
	Delay When Entering and/or Leaving enabled. Learn more
	Superior DoorProtect G3 Fibra will operate when Night Mode is enabled. Learn more
	The opening sensor has detected the opening. The icon is displayed regardless of the security mode.
	The external contact (the third-party wired detector) has detected the opening. The icon is displayed regardless of the security mode.
	The roller shutter detector is disconnected.
	The magnetic masking was detected.
	The magnetic masking sensor requires calibration.
	Superior DoorProtect G3 Fibra is permanently deactivated. Learn more

	<p>The detector has tamper triggering events permanently deactivated.</p> <p><u>Learn more</u></p>
	<p>Superior DoorProtect G3 Fibra has been deactivated due to exceeding the preset number of alarms.</p> <p><u>Learn more</u></p>
	<p>Superior DoorProtect G3 Fibra is deactivated for a time the armed mode is active.</p> <p><u>Learn more</u></p>
	<p>Superior DoorProtect G3 Fibra has tamper triggering events deactivated for a time the armed mode is active.</p> <p><u>Learn more</u></p>
<div data-bbox="261 1073 380 1119" style="border: 1px solid red; border-radius: 5px; padding: 2px; display: inline-block;">Offline</div>	<p>The device has lost connection with the hub or the hub has lost connection with the Ajax Cloud server.</p>
<div data-bbox="224 1247 420 1281" style="border: 1px solid red; border-radius: 5px; padding: 2px; display: inline-block;">Not transferred</div>	<p>The device has not been transferred to the new hub.</p> <p><u>Learn more</u></p>

States

The states include information about the device and its operating parameters. The states of Superior DoorProtect G3 Fibra can be found in Ajax apps:

1. Go to the **Devices**  tab.
2. Select **Superior DoorProtect G3 Fibra** from the list.

Parameter	Meaning
Data import	<p>Displays the error when transferring data to the new hub:</p> <ul style="list-style-type: none"> • Failed – the device has not been transferred to the new hub. <p>Learn more</p>
Malfunction	<p>Clicking on ⓘ opens the list of the detector malfunctions.</p> <p>The field is displayed only if a malfunction is detected.</p>
Magnetic masking sensor requires calibration	<p>The magnetic masking sensor requires calibration. Calibration is important for the device's correct operation and instant detection of the attempt to use fraudulent magnets.</p> <p>Learn more</p>
Temperature	<p>Detector temperature.</p> <p>The acceptable error between the value in the app and the temperature at the installation site: 2°C.</p> <p>The value is updated as soon as the device detects a temperature change of at least 1°C.</p> <p>You can create a scenario by temperature to control automation devices.</p> <p>Learn more</p>
Fibra Signal Strength	<p>Signal strength between the hub and Superior DoorProtect G3 Fibra. Recommended values: 2–3 bars.</p>

	<p>Fibra is a protocol for transmitting events and alarms.</p> <p><u>Learn more</u></p>
Connection via Fibra	<p>The status of the connection between the hub and the detector:</p> <ul style="list-style-type: none">• Online – the detector is connected to the hub.• Offline – the detector has lost connection with the hub. Check the detector connection to the hub.
Line Voltage	<p>The voltage value on the Fibra line to which the detector is connected.</p>
Lid	<p>The tamper status that responds to the detachment of the device from the surface or violation of the device’s enclosure integrity:</p> <ul style="list-style-type: none">• Front lid open – the integrity of the front panel of the enclosure has been violated.• Closed – the detector is installed on the mounting panel. The normal state of the enclosure.• Detached from surface – the detector is removed from the mounting panel.• Detached from surface and front lid open – the detector is removed from the mounting panel, and the integrity of the enclosure has been violated. <p><u>Learn more</u></p>
Opening sensor	<p>Status of the detector’s opening sensor:</p> <ul style="list-style-type: none">• Disabled – sensor is deactivated.

	<ul style="list-style-type: none"> • Open – sensor is open. • Closed – sensor is closed.
External Contact	<p>The status of the third-party detector connected to Superior DoorProtect G3 Fibra:</p> <ul style="list-style-type: none"> • Disabled – the external contact is disabled (the option is disabled in the app). • Open – the external contact is connected and in the open state. • Closed – the external contact is connected and in the closed state.
Shock Sensor	<p>Indicates if the shock sensor is active:</p> <ul style="list-style-type: none"> • On – the shock sensor is on. • Off – the shock sensor is off.
Tilt Sensor	<p>Indicates if the tilt sensor is active:</p> <ul style="list-style-type: none"> • On – the tilt sensor is on. • Off – the tilt sensor is off.
Magnetic Masking Detection	<p>Shows the status of the magnetic masking detection:</p> <ul style="list-style-type: none"> • Enabled – the option is on. • Off – the option is disabled. • Alert – the magnetic masking detected.
Always Active	<p>When this option is enabled, the detector is constantly armed, detects the opening and</p>

	<p>closing of a door or a window, impact, and changes in angle and raises alarms.</p> <p><u>Learn more</u></p>
Permanent Deactivation	<p>Shows the status of the device's deactivation setting:</p> <ul style="list-style-type: none">• No – the device operates in normal mode and transmits all events.• Lid only – the hub admin has disabled notifications about tamper triggering.• Entirely – the hub admin has entirely excluded the detector from the system. The device does not follow system commands or report alarms or other events.• By number of alarms – the device is automatically excluded from the system when the number of alarms is exceeded. The number of alarms is specified in the <u>Devices Auto Deactivation</u> hub settings in Ajax PRO-app. <p><u>Learn more</u></p>
One-Time Deactivation	<p>Shows the status of the device one-time deactivation setting:</p> <ul style="list-style-type: none">• No – the device operates in the normal mode.• Lid only – notifications on the tamper triggering are disabled for a time the armed mode is active.• Entirely – the detector is entirely excluded from the operation of the system for a time the armed mode is active. The device does not execute system commands and does not report alarms or other events.

[Learn more](#)

Alarm Reaction

Operating Mode

Shows how the detector reacts to alarms:

- **Instant Alarm** – the armed detector immediately reacts to a threat and raises the alarm.
- **Entry/Exit** – when a delay is set, the armed device starts the countdown and doesn't raise the alarm even if triggered until the countdown ends.
- **Follower** – the detector inherits the delays from Entry/Exit detectors. However, when the Follower is triggered individually, it immediately raises the alarm.

Delay When Entering, sec

Delay when entering (alarm activation delay) is the time the user has to disarm the security system after entering the premises.

[Learn more](#)

Delay When Leaving, sec

Delay when leaving (arming delay) is the time the user has to leave the premises after arming.

[Learn more](#)



Arm in Night Mode

When this option is enabled, the detector will enter the armed mode when the system is set to **Night Mode**.

Night Mode Delay When Entering, sec	Entry delay time in Night Mode . Delay when entering (alarm activation delay) is the time the user has to disarm the security system after entering the premises. <u>Learn more</u>
Night Mode Delay When Leaving, sec	Leaving delay time in Night Mode . Delay when leaving (arming delay) is the time the user has to leave the premises after enabling Night Mode. <u>Learn more</u>
Firmware	Detector firmware version.
Device ID	Detector ID. Also available on the QR code on the detector enclosure and its package box.
Device No.	Device number. This number is transmitted to the CMS in case of an alarm or event.
Line No.	The number of the hub's Fibra line to which the device is connected. Displayed in case of Beam (Radial) connection.
Ring No.	The number of the hub's Fibra ring to which the device is connected. Displayed in case of Ring connection.

Settings

To change Superior DoorProtect G3 Fibra settings in the Ajax apps:

1. Go to the **Devices**  tab.
2. Select **Superior DoorProtect G3 Fibra** from the list.
3. Go to **Settings** by clicking on the gear icon .

4. Set the required parameters.

5. Click **Back** to save the new settings.

Settings	Meaning
Name	<p>Name of the detector. Displayed in the list of hub devices, SMS text and notifications in the event feed.</p> <p>To change the name of the detector, click on the text field.</p> <p>The name can contain up to 12 Cyrillic characters or up to 24 Latin characters.</p>
Room	<p>Selection of the Superior DoorProtect G3 Fibra virtual room.</p> <p>The room name is displayed in the text of SMS and notifications in the events feed.</p>
Alarm LED indication	<p>When the option is disabled, the LED indicator of the detector doesn't notify about alarms or tamper triggering.</p>
Opening sensor	<p>If active, Superior DoorProtect G3 Fibra opening sensor responds to opening and closing.</p> <p>When this option is disabled, the Magnetic Masking Detection function is unavailable.</p>
External Contact	<p>If active, Superior DoorProtect G3 Fibra registers alarms of a third-party wired detector connected to it.</p>
Always Active	<p>When this option is enabled, the detector is always armed.</p> <p>This means the detector will constantly respond to opening/shock/tilt and raise</p>

	<p>alarms regardless of the system arming mode.</p> <p>Learn more</p>
<p>External Contact Type</p>	<p>Selecting the type of a third-party wired detector connected to Superior DoorProtect G3 Fibra terminals:</p> <ul style="list-style-type: none"> • External Contact – any third-party detector with NC (normally closed) contact. • Roller Shutter – roller shutter motion detector.
<p>Time Before Alarm, sec</p>	<p>The time for which the specified number of impulses should be counted: 5 to 30 seconds.</p> <p>Counted after the first impulse from the roller shutter detector connected to Superior DoorProtect G3 Fibra.</p> <p>This setting is displayed if the type of external contact is Roller Shutter.</p>
<p>Impulses Before Alarm</p>	<p>A number of impulses from the roller shutter detector connected to Superior DoorProtect G3 Fibra, which is required to raise an alarm: 2 to 7.</p> <p>This setting is displayed if the type of external contact is Roller Shutter.</p>
<p>Shock Sensor</p>	<p>When this option is enabled, the device detects shocks.</p>
<p>Sensitivity</p>	<p>Shock sensor sensitivity level. The choice depends on the type of the object, the presence of probable sources of false alarms, and the specifics of the protected area:</p>

	<ul style="list-style-type: none"> • Low – there are likely sources of false alarms in the protected area. For example, vibration from freight machines driving by. • Normal (default value) – recommended value suitable for most objects. Do not change it if the detector works correctly. • High – there is no interference in the protected area; the maximum sensitivity of detection and the alarm detection speed are important. <p>Before selecting the sensitivity level, conduct the detection zone test. If the detector doesn't react to shock in 5 cases out of 5 during the test, the sensitivity should be increased.</p>
Ignore Simple Impact	When this option is enabled, the alarm is activated only if the sensor detects more than one shock.
Tilt Sensor	When this option is enabled, the device detects a change in the tilt angle.
Tilt	Selection of the initial value of the tilt angle of the detector. The sensor detects an alarm if the tilt angle value changes.
Tilt Alarm Delay	The time from the moment the detector is tilted to the alarm: 1 second to 1 minute.
Magnetic Masking Detection	<p>When this option is enabled, the device detects the magnetic masking.</p> <p>This setting is displayed if the Opening sensor option is enabled.</p>
Masking Detection Sensitivity	The sensitivity level of the magnetic masking sensor. The choice depends on the type of the object, the presence of probable sources of false alarms, and the specifics of the protected area:

	<ul style="list-style-type: none"> • Low. • Normal (default value). • High. <p>If the detector is installed on a door with a door closer, the High sensitivity level not should be set.</p>
Detect Masking	<p>Selection of when the device detects magnetic masking:</p> <ul style="list-style-type: none"> • Always – if selected, a magnetic masking attempt will be detected as a malfunction regardless of the device’s armed mode. • Only when armed – if selected, a magnetic masking attempt will trigger an alarm only when the device is armed. <div data-bbox="833 1056 1401 1283" style="border: 1px solid black; border-radius: 10px; padding: 10px; margin-top: 10px;">  The setting is available when the detector is connected to hubs with firmware version OS Malevich 2.19 or higher. </div>
Alert with a siren	
If opening detected	If active, sirens added to the system are activated when the opening detected.
If an external contact is opened	<p>If active, sirens added to the system are activated during an external detector alarm.</p> <p>This setting is displayed if the type of external contact is External Contact.</p>
If roller shutter triggered	If active, sirens added to the system are activated when the roller shutter connected to

	<p>Superior DoorProtect G3 Fibra detects an alarm.</p> <p>This setting is displayed if the type of external contact is Roller Shutter.</p>
If roller shutter is disconnected	<p>If active, sirens added to the system are activated when the roller shutter detector connected to Superior DoorProtect G3 Fibra is disabled.</p> <p>This setting is displayed if the type of external contact is Roller Shutter.</p>
If shock detected	<p>If active, sirens added to the system are activated when Superior DoorProtect G3 Fibra detects a shock.</p>
If tilt detected	<p>If active, sirens added to the system are activated when Superior DoorProtect G3 Fibra detects a tilt.</p>
If magnetic masking detected	<p>If active, sirens added to the system are activated when the magnetic masking is detected.</p>
Chime Settings	<p>When Chime (opening notifications) is enabled, the sirens make a special sound to indicate that the opening detectors are triggered when the system is disarmed.</p> <p>Learn more</p>
Alarm Reaction	
Operating Mode	<p>Specify how this device will react to alarms:</p> <ul style="list-style-type: none"> • Instant Alarm – the armed detector immediately reacts to a threat and raises the alarm. • Entry/Exit – when a delay is set, the armed device starts the countdown and

	<p>doesn't raise the alarm even if triggered until the countdown ends.</p> <ul style="list-style-type: none">• Follower – the detector inherits the delays from Entry/Exit detectors. However, when the Follower is triggered individually, it immediately raises the alarm.
Delay When Entering, sec	<p>Selecting delay time when entering: 5 to 120 seconds.</p> <p>Delay when entering (alarm activation delay) is the time the user has to disarm the security system after entering the premises.</p> <p><u>Learn more</u></p>
Delay When Leaving, sec	<p>Selecting delay time when leaving: 5 to 120 seconds.</p> <p>Delay when leaving (arming delay) is the time the user has to leave the premises after arming.</p> <p><u>Learn more</u></p>
Arm in Night Mode	<p>When this option is enabled, the detector will enter the armed mode when the system is set to Night Mode.</p> <p><u>Learn more</u></p>
Night Mode Delay When Entering, sec	<p>Delay time when entering in Night Mode.</p> <p>Delay when entering (alarm activation delay) is the time the user has to disable Night Mode after entering the premises.</p> <p><u>Learn more</u></p>
Night Mode Delay When Leaving, sec	<p>Delay time when leaving in Night Mode.</p>

	<p>Delay when leaving (arming delay) is the time the user has to leave the premises after enabling Night Mode.</p> <p><u>Learn more</u></p>
Fibra Signal Strength Test	<p>Puts the detector into the Fibra Signal Strength Test mode.</p> <p>The test allows you to check the signal strength between the hub and the detector via the wired Fibra data transfer protocol to select the optimal installation site.</p> <p><u>Learn more</u></p>
Detection Zone Test	<p>Switches the detector to the detection zone test mode.</p> <p>The test enables users to check how the detector responds to the opening and closing of a door or a window, impact, and changes in angle and determine the optimal installation location.</p> <p><u>Learn more</u></p>
Calibration of Masking Sensor	<p>Runs the calibration of the masking sensor to ensure the correct operation of the device and instant detection of the attempt to use fraudulent magnets.</p> <p><u>Learn more</u></p>
Device Self-Test	<p>Runs the detector self-test.</p> <div data-bbox="834 1801 1401 2028" style="border: 1px solid black; border-radius: 10px; padding: 10px;"><p> Testing is available when the detector is connected to hubs with firmware version OS Malevich 2.19 or higher.</p></div>

	<p><u>Learn more</u></p>
User Guide	<p>Opens the Superior DoorProtect G3 Fibra user manual in the Ajax app.</p>
Permanent Deactivation	<p>Allows the user to disable events of the device without removing it from the system.</p> <p>Three options are available:</p> <ul style="list-style-type: none">• No – the device operates in normal mode and transmits all events.• Entirely – the device will not execute system commands or participate in automation scenarios, and the system will ignore device alarms and other notifications.• Lid only – the system will ignore notifications about the triggering of the device tamper only. <p><u>Learn more</u></p> <p>The system can also automatically deactivate devices when the set number of alarms is exceeded or when the recovery timer expires.</p> <p><u>Learn more</u></p>
One-Time Deactivation	<p>Allows the user to disable events of the device until the first disarm.</p> <p>Three options are available:</p> <ul style="list-style-type: none">• No – the device operates in the normal mode.• Lid only – notifications on the tamper triggering are disabled until the first disarm.

	<ul style="list-style-type: none"> • Entirely – the detector is entirely excluded from the operation of the system until the first disarm. The device does not execute system commands and does not report alarms or other events. <p>Learn more</p>
Unpair Device	Unpairs the detector, disconnects it from the hub, and deletes its settings.

How to set up Chime

The **Chime** is an audio signal about triggering the opening detectors when the system is disarmed. The feature is used, for example, in stores, to notify employees that someone has entered the premises.

Notifications are configured in two stages: setting up sirens and setting up opening detectors.

[How to set up a detector](#)

[How to set up a Chime siren](#)

How to run calibrating the magnetic masking sensor

Calibration of the magnetic masking sensor is important for the correct operation of the device and instant detection of the attempt to use fraudulent magnets. The sensor should be calibrated immediately after [adding it to the system](#) or if the installation location has been changed.

To start calibrating the masking sensor, in the Ajax app:



1. Go to the **Devices**  tab.

2. Select Superior DoorProtect G3 Fibra from the list.
3. Go to the calibration by clicking on  in front of the **Magnetic masking sensor requires calibration** state.



To calibrate the device, ensure that the opening sensor is closed and no fraudulent magnets are nearby.



If the icon  is not available, in the Ajax app:

1. Go to the **Devices**  tab.
2. Select Superior DoorProtect G3 Fibra from the list.
3. Go to **Settings** by clicking on the gear icon .
4. Go to the **Calibration of Masking Sensor** menu.
5. Click **Start**.
6. If the calibration is successful, click **Close** to return to the settings. If the device fails to calibrate, check if the device is installed properly and the opening sensor contact is closed. Click **Restart**.

How to run device self-testing

Device self-testing allows users to check if the device's built-in sensors operate properly. During the self-test, the opening sensor, accelerometer, and magnetic sensor will be tested.

To run self-testing, in the Ajax app:

1. Go to the **Devices**  tab.
2. Select Superior DoorProtect G3 Fibra from the list.
3. Go to **Settings** by clicking on the gear icon .

4. Go to the **Device Self-Test** menu.



To run self-testing, ensure that the system is disarmed, and another test is not in progress.

5. Click **Start**.

6. If self-testing is successful, click **Done** to return to the settings. If some sensors are faulty, we recommend contacting the service center.

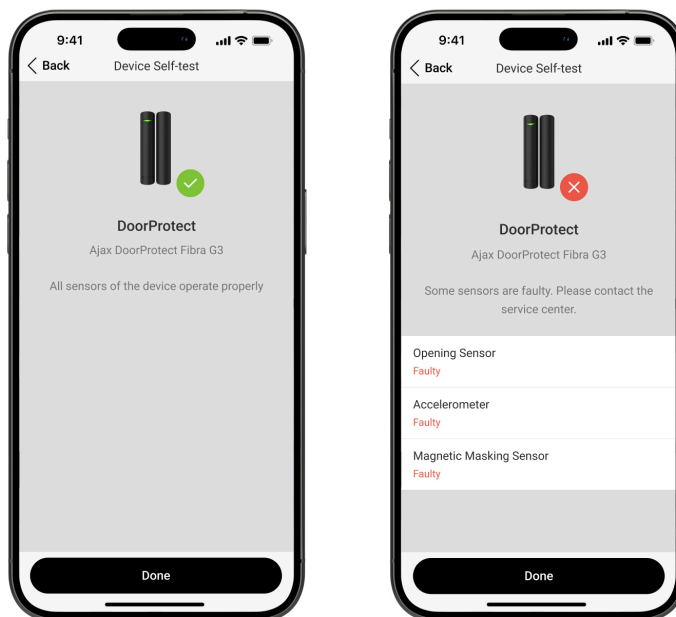

Note that on hubs with [OS Malevich 2.36](#) and later, the device self-test checks only the enabled sensors of the device.

If a faulty sensor is disabled, the system will not show the malfunction counter in an Ajax app and will not notify users about the sensor malfunction. However, if a user enables a faulty sensor, the system will send a notification that the sensor is malfunctioning.

Users and the CMS will receive a corresponding notification about the testing result after completion.

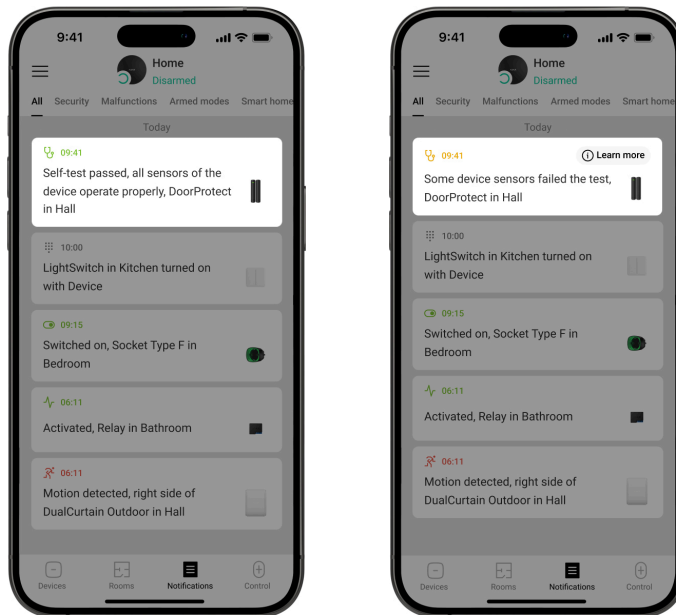

Indication

Indication	Event	Note
Lights up green for about a second.	Switching on the detector.	The detector turns on as soon as the hub is powered up.
Lights up for a couple of seconds until the detector is connected to the hub.	Connecting the detector to the hub.	
Lights up green for about a second.	Alarm/tamper triggering.	
Slowly lights up green and slowly goes out (after an alarm or tamper triggers).	Low voltage on the Fibra line.	A voltage of 7 V _{DC} or less is considered low. Check the wiring of the detector.
Lights up green for about a second.	Detection of masking.	The detector signals masking even if the LED alarm indication is turned off.
Flashes rapidly twice.	The calibration of the masking sensor was	

Maintenance

Check the functioning of the detector regularly. Clean the device enclosure of dust, cobwebs, and other contaminants as they emerge. Use soft dry wipes suitable for equipment care.

Do not use substances that contain alcohol, acetone, petrol, and other active solvents to clean the detector.

Technical specifications

[All technical specifications](#)

[Compliance with standards](#)

[Setup in compliance with EN 50131 requirements](#)

Warranty

Warranty for the Limited Liability Company “Ajax Systems Manufacturing” products is valid for 2 years after the purchase.

If the device does not function correctly, please contact the Ajax Technical Support first. In most cases, technical difficulties can be resolved remotely.

[Warranty obligations](#)

[User agreement](#)

Contact Technical Support:

- e-mail
- Telegram